

FEEDWAY™

OIL LEVEL CONTROL



FP-ERL3. Oil level regulator.

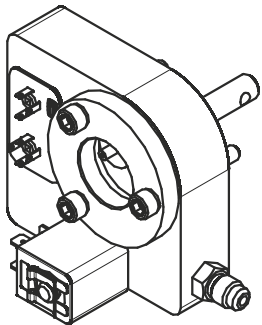

Fig.1. General view

Application

Oil level regulator FP-ERL (fig.1) is designed for installation in oil circuit of compressor stations in order to control, maintain oil level in the crankcase of compressor, emergency alarming and turning off compressor in case of low oil pressure in crankcase. Device belongs to active methods of oil level controlling and designed to work with full pressure drops.

Safety instructions

- ⚠ Carefully read this instruction. Ignoring these rules may lead to malfunctioning of this device, staff injuries and malfunctioning of compressor.
- ⚠ Installation and service must be done by qualified staff with appropriate level of knowledge and skills as well as access to electrical works of relevant class.
- ⚠ Follow the instruction in part of air temperature, do not exceed maximum allowed working pressure, control working voltage range, mentioned in the technical characteristics of device.
- ⚠ Follow the electrical connection sketch of oil level regulator.
- ⚠ Electromagnetic waves may have a negative effect on device operation, shield it if necessary.

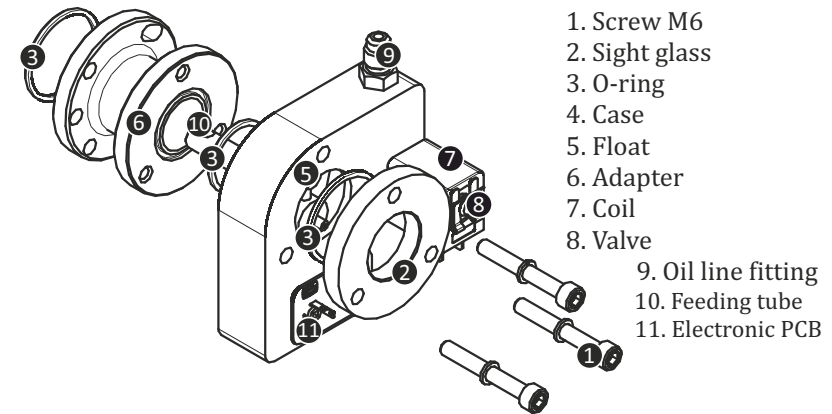

1. Screw M6
2. Sight glass
3. O-ring
4. Case
5. Float
6. Adapter
7. Coil
8. Valve
9. Oil line fitting
10. Feeding tube
11. Electronic PCB

Fig.2. Assembly drawing

Installation instruction

- Prior to installation make sure that pressure in the system is equal to surrounding's and dismantle the sight glass of compressor
- Connect adapter to compressor firmly using gaskets supplied together with device.
- Connect oil level regulator FP-ERL to compressor as shown in fig.2. If necessary use the original compressor's screws. Keep the sight glass screws strain level on 9Nm.
- Put the body of oil level regulator strictly horizontal. Maximum allowed deviation is +-1.
- Is not recommended to connect pins of alarm relay directly to compressor.
- Electric connections done by DIN43650 connectors. Electric connection scheme is shown in fig.3.
- During operation it is recommended to keep regulator switched on even when compressor is disconnected from power.

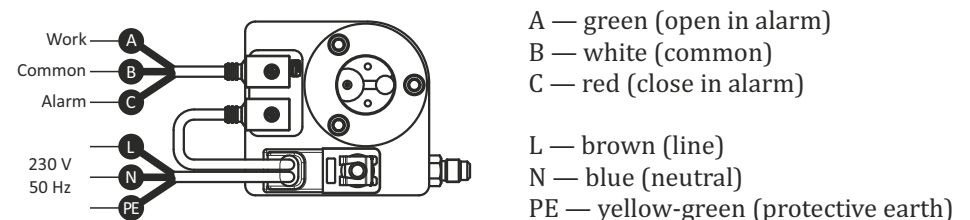

- A — green (open in alarm)
- B — white (common)
- C — red (close in alarm)











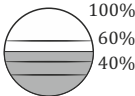

- L — brown (line)
- N — blue (neutral)
- PE — yellow-green (protective earth)

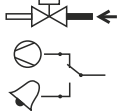
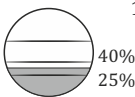
Fig.3. Electrical Connection

How it works

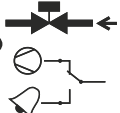
There are three levels of oil control (40%-60% - working oil level, 25%-40% - risky oil level, 0%-25% - emergency oil level, fig.1) When switched off the indicators are not lighting, alarm contact relay is closed. In nominal mode oil level is more than 40%, green indicator "High oil level" is on. When oil level goes lower than 40% but not less than 25%, after 10 seconds delay the yellow indicator starts to light and oil starts to run into compressor crankcase. When oil level goes higher than 40% green indicator starts to light, yellow indicator also lights, oil runs into compressor until oil level goes higher than 60%. When oil level goes lower than 25% yellow indicator starts to light and oil starts to run into compressor immediately, if oil level do not rise higher than 25% during next 120 seconds the red indicator "Emergency oil level" goes on and emergency contact relay is closed.

Tab.1.Oil level control

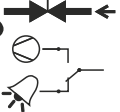
Oil level	Range	Indication	State
Normal oil level. Oil level 40%-100%. Valve is closed. Contact «Work» is closed	 100% 60% 40%	 green  	
Critical oil level. Oil level 25%-40% Valve is opened. Contact «Work» is closed	 10 sec 40% 25%	 yellow  	
Alarm oil level. Oil level 0%-25% Valve is opened. Contact «Alarm» is closed	 120 sec 25% 0%	 yellow  red	

Storage

Storage controller in closed ventilated warehouse, in dry, clean and chemically not aggressive environment. If this is not possible, it is necessary to protect the regulator from the negative effects of the environment.

Dismantling and utilization

Dismantle valve in the following sequence:

- Prior to dismantling valve make sure that pressure in the refrigeration circuit equals the surrounding's.
- Utilization of regulator is done separately from the printed circuit board, in accordance with national regulations.

Tab.2.Technical data

Parameters	Value
Исполнение:	ERL3
Max. operating pressure PS:	4.0 MPa
Max. testing pressure PT:	5.0 MPa
Burst pressure	20.0 MPa
Power supply	230 V, 50/60Hz, 0.04A
Consumed power	15 VA
MOPD	2.4 MPa
Ambient air/storage temperature	-20...+50 °C,
Operating environment temperature (oil)	-40...+80 °C,
Ingress protection rating	IP54
Delay oil supply	10 sec
Delay alarm relay	120 sec
Oil level range maintance	40%...60% of the height of the sight glass
Alarm relay	max. 3A, 230V, 50/60Hz
Case material	Silumin
Power supply cable length	3 m
Orientation	havig flat horizontal, $\pm 1^\circ$
Solenoid valve connection	DIN43650 B
Alarm relay and power supply connection	DIN43650 C
Oil line adapter	Thread 7/16"-20UNF

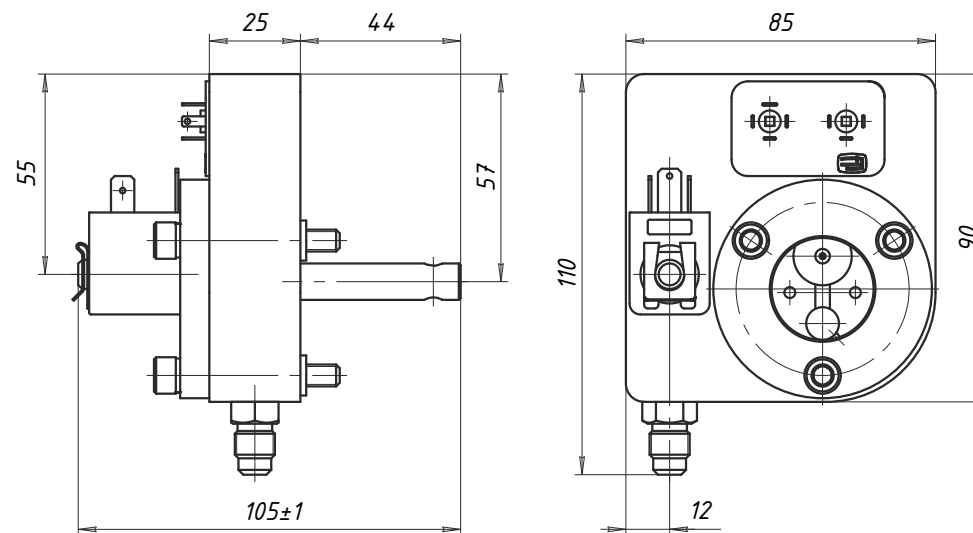

Fig.4. Dimensions